

- Introducing the **Patented** Corner Seal ■ Eliminates Wasteful Miter Cutting
 - Makes the current labor-intensive corner seal assembly obsolete
 - Easy **4-step process** for increased line efficiency *Patent#6,527,278 B1*

Step 1:

Purchase the **patented** Corner Seal

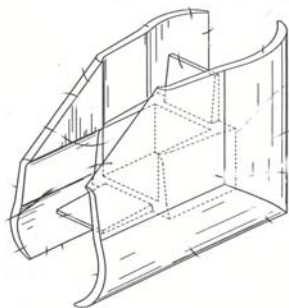

Step 2:

Square cut your gaskets and apply to Swing Door

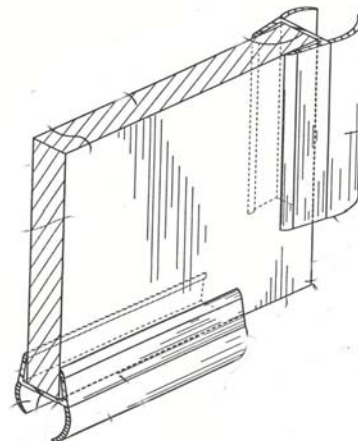

Step 3:

Apply the quick dry adhesive to the Corner Seal and the door

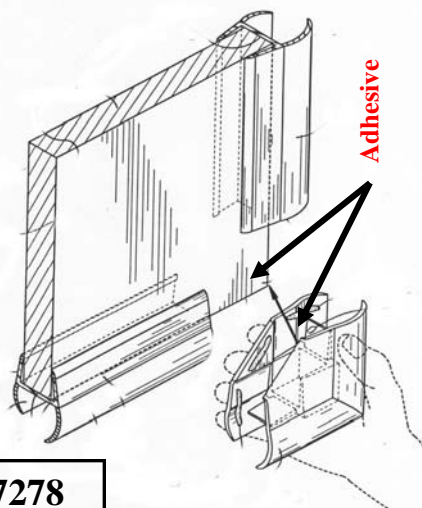

Step 4:

Clamp Corner Seal and assembly is finished

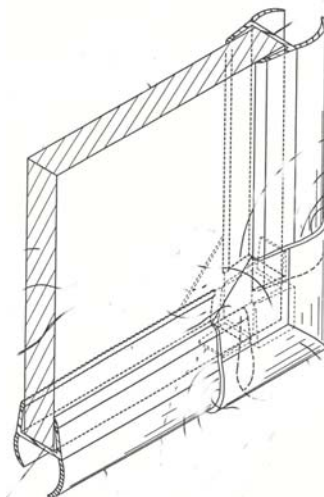

3/4" Part # 527278

1/2" Part # 527250

The Corner Seal Advantage

- Eliminate Miter Cut Gaskets
- Eliminate Miter Cut Waste
- Eliminate Sonic Welding
- Mates with 1/2" or 3/4" gasket
- Proven to reinforce corner of swing door

Drastically Reduce Labor Costs
Increase Productivity
Increase Your Margins

U.S. Office

5765 S. St. Rt. 48, Bldg 110
Suite 131
Maineville, OH 45039
Ph 888-893-1643
Fx 888-893-1643
sales@norstarintl.com

For more information visit our web site

www.norstarintl.com

or Email

sales@norstarintl.com

China Office

1565 Jiao Tong Rd. Rm 1606
Tong Lian Bldg
Pu Tuo
Shanghai, China 200065
Ph 86-21-5653-1608
Fx 86-21-5653-1607